

**Robert Bosch GmbH**

Power Tools Division
70745 Leinfelden-Echterdingen
Germany

www.bosch-pt.com

2 609 140 773 (2011.08) O / 190 XXX



2 609 140 773

GLM 50 Professional

de Originalbetriebsanleitung	pl Instrukcja oryginalna	lv Instrukcijas oriģinālvalodā
en Original instructions	cs Původní návod k používání	lt Originali instrukcija
fr Notice originale	sk Pôvodný návod na použitie	cn 正本使用说明书
es Manual original	hu Eredeti használati utasítás	tw 正本使用說明書
pt Manual original	ru Оригинальное руководство по эксплуатации	ko 사용 설명서 원본
it Istruzioni originali	uk Оригінальна інструкція з експлуатації	ar تعليمات التشغيل الأصلية
nl Oorspronkelijke gebruiksaanwijzing	ro Instrucțiuni originale	fa راهنمای طرز کار اصلی
da Original brugsanvisning	bg Оригинална инструкция	
sv Bruksanvisning i original	sr Originalno uputstvo za rad	
no Original driftsinstruks	sl Izvirna navodila	
fi Alkuperäiset ohjeet	hr Originalne upute za rad	
el Πρωτότυπο οδηγιών χρήσης	et Algupärane kasutusjuhend	
tr Orijinal işletme talimatı		



Deutsch.....	Seite	6
English	Page	11
Français	Page	18
Español	Página	25
Português	Página	31
Italiano	Pagina	37
Nederlands	Pagina	43
Dansk	Side	49
Svenska	Sida	54
Norsk.....	Side	59
Suomi	Sivu	64
Ελληνικά	Σελίδα	69
Türkçe.....	Sayfa	75
Polski	Strona	80
Česky	Strana	86
Slovensky	Strana	92
Magyar	Oldal	97
Русский	Страница	103
Українська	Сторінка	110
Română.....	Pagina	116
Български.....	Страница	121
Srpski	Strana	128
Slovensko	Stran	133
Hrvatski.....	Stranica	138
Eesti	Lehekülj	144
Latviešu	Lappuse	149
Lietuviškai.....	Puslapis	155
中文.....	頁	160
中文.....	頁	165
한국어.....	면	170
عربي	صفحة	182
فارسی	صفحه	189

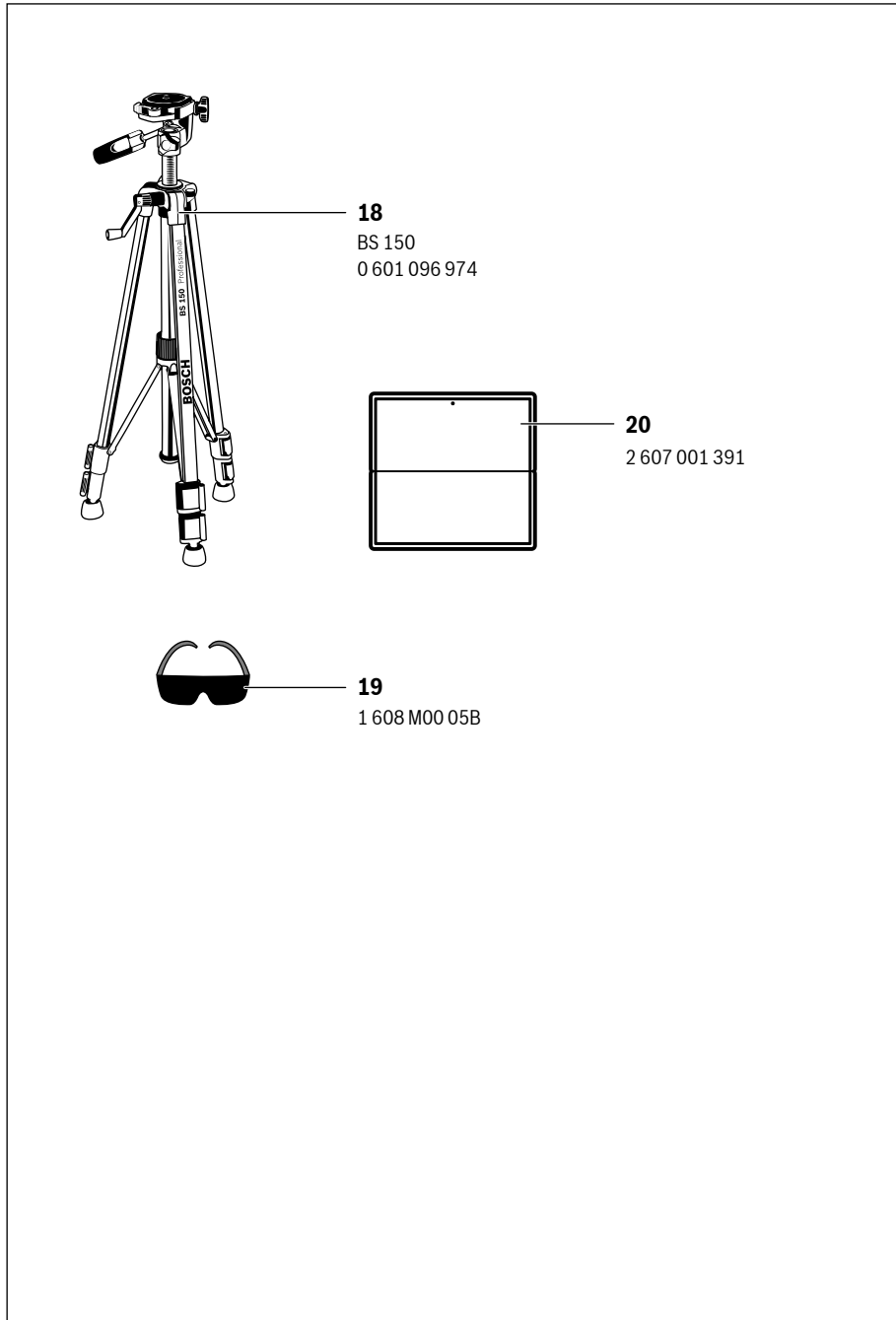

18
BS 150
0 601 096 974

20
2 607 001 391

19
1 608 M00 05B

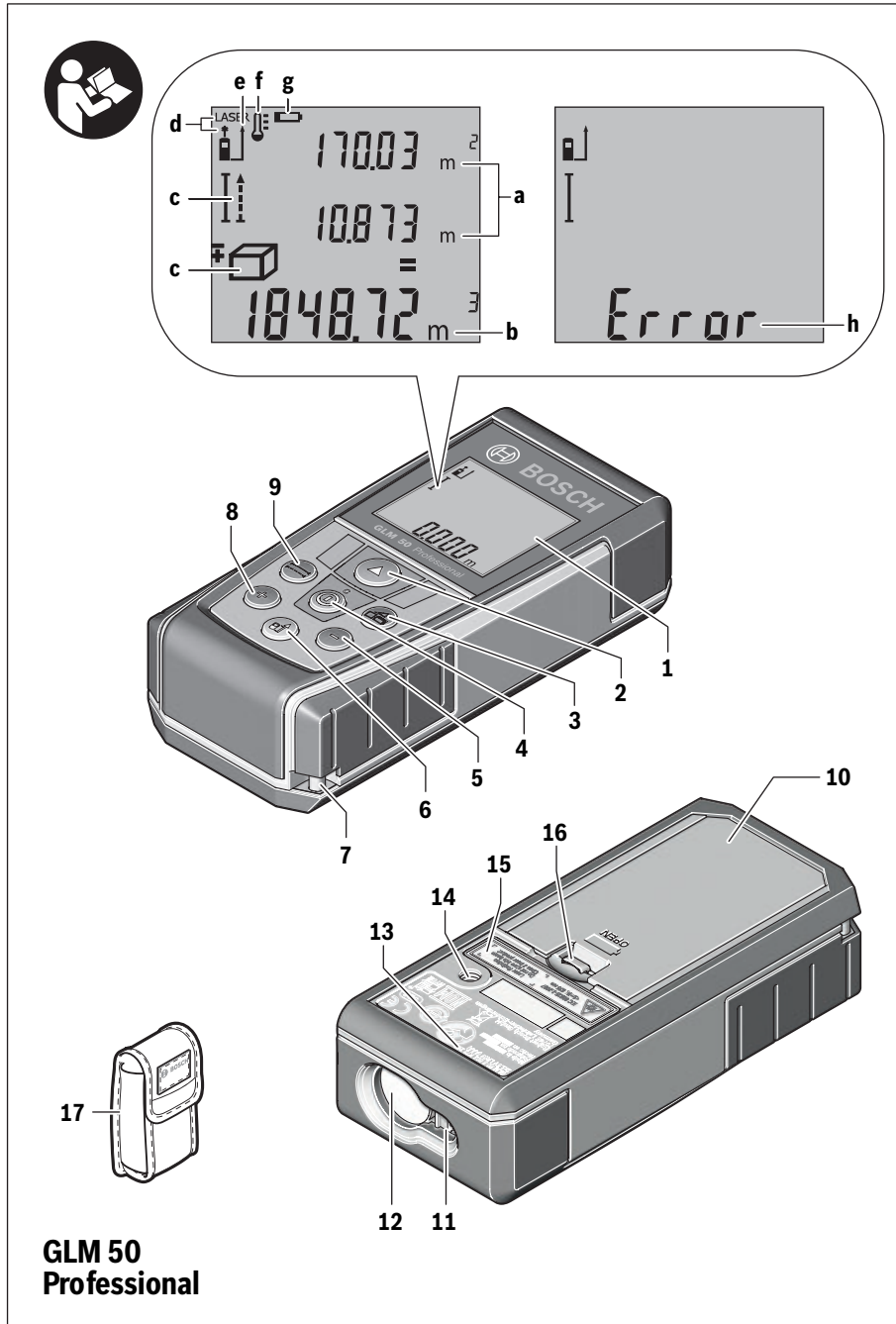

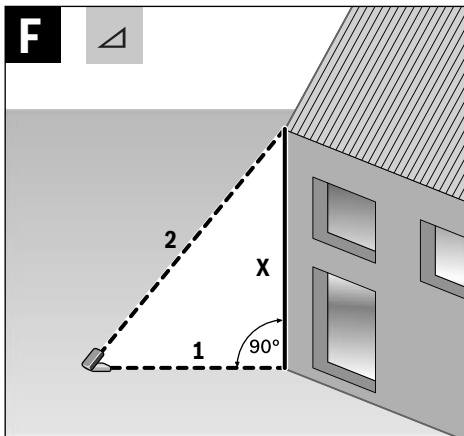
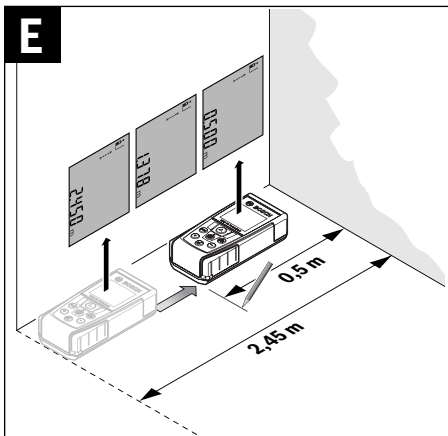
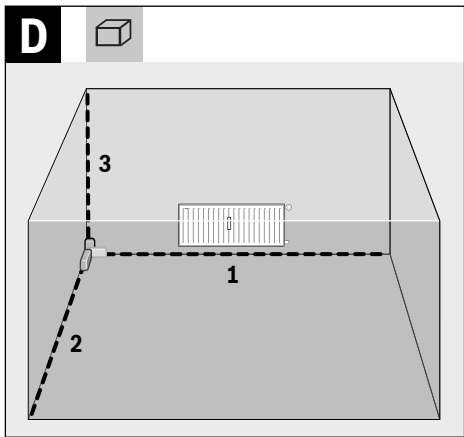
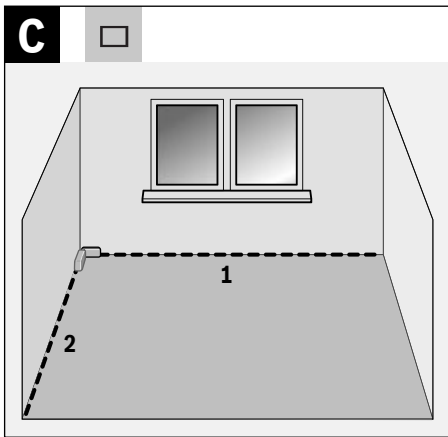
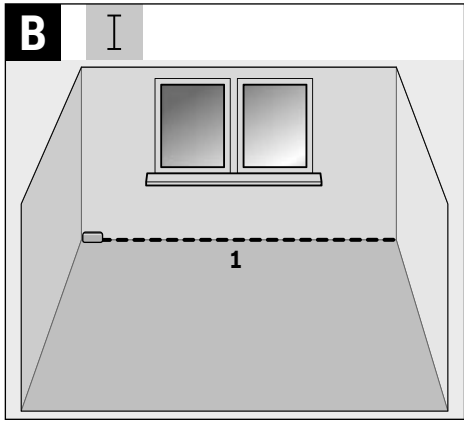
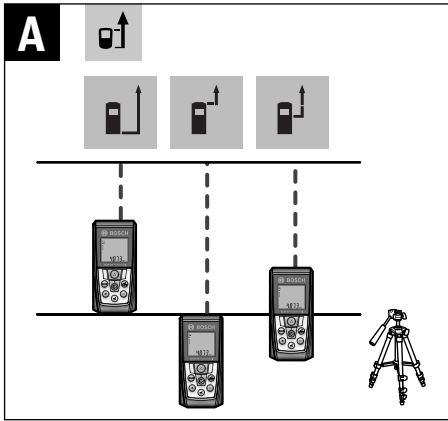

Wartung und Service

Wartung und Reinigung

Lagern und transportieren Sie das Messwerkzeug nur in der mitgelieferten Schutztasche.

Halten Sie das Messwerkzeug stets sauber.

Tauchen Sie das Messwerkzeug nicht ins Wasser oder andere Flüssigkeiten.

Wischen Sie Verschmutzungen mit einem feuchten, weichen Tuch ab. Verwenden Sie keine Reinigungs- oder Lösemittel. Pflegen Sie insbesondere die Empfangslinse **12** mit der gleichen Sorgfalt, mit der Brille oder Linse eines Fotoapparats behandelt werden müssen.

Sollte das Messwerkzeug trotz sorgfältiger Herstellungs- und Prüfverfahren einmal ausfallen, ist die Reparatur von einer autorisierten Kundendienststelle für Bosch-Elektrowerkzeuge ausführen zu lassen. Öffnen Sie das Messwerkzeug nicht selbst.

Geben Sie bei allen Rückfragen und Ersatzteilbestellungen bitte unbedingt die 10-stellige Sachnummer laut Typenschild des Messwerkzeugs an.

Senden Sie im Reparaturfall das Messwerkzeug in der Schutztasche **17** ein.

Kundendienst und Kundenberatung

Der Kundendienst beantwortet Ihre Fragen zu Reparatur und Wartung Ihres Produkts sowie zu Ersatzteilen. Explosionszeichnungen und Informationen zu Ersatzteilen finden Sie auch unter:

www.bosch-pt.com

Das Bosch-Kundenberater-Team hilft Ihnen gerne bei Fragen zu Kauf, Anwendung und Einstellung von Produkten und Zubehör.

www.powertool-portal.de, das Internetportal für Handwerker und Heimwerker.

www.ewbc.de, der Informations-Pool für Handwerk und Ausbildung.

Deutschland

Robert Bosch GmbH
Servicezentrum Elektrowerkzeuge
Zur Luhne 2
37589 Kalefeld – Willershausen
Tel. Kundendienst: +49 (1805) 70 74 10*
Fax: +49 (1805) 70 74 11*
(*Festnetzpreis 14 ct/min, höchstens 42 ct/min aus Mobilfunknetzen)
E-Mail: Servicezentrum.Elektrowerkzeuge@de.bosch.com
Tel. Kundenberatung: +49 (1803) 33 57 99
(Festnetzpreis 9 ct/min, höchstens 42 ct/min aus Mobilfunknetzen)
Fax: +49 (711) 7 58 19 30
E-Mail: kundenberatung.ew@de.bosch.com

Österreich

Tel.: +43 (01) 7 97 22 20 10
Fax: +43 (01) 7 97 22 20 11
E-Mail: service.elektrowerkzeuge@at.bosch.com

Schweiz

Tel.: +41 (044) 8 47 15 11
Fax: +41 (044) 8 47 15 51

Luxemburg

Tel.: +32 2 588 0589
Fax: +32 2 588 0595
E-Mail: outillage.gereedschap@be.bosch.com

Entsorgung

Messwerkzeuge, Zubehör und Verpackungen sollen einer umweltgerechten Wiederverwertung zugeführt werden.

Werfen Sie Messwerkzeuge und Akkus/Batterien nicht in den Hausmüll!

Nur für EU-Länder:



Gemäß der europäischen Richtlinie 2002/96/EG müssen nicht mehr gebrauchsfähige Messwerkzeuge und gemäß der europäischen Richtlinie 2006/66/EG müssen defekte oder verbrauchte Akkus/Batterien getrennt gesammelt und einer umweltgerechten Wiederverwendung zugeführt werden. Nicht mehr gebrauchsfähige Akkuzellen/Batterien können direkt abgegeben werden bei:

Deutschland

Recyclingzentrum Elektrowerkzeuge
Osteröder Landstraße 337589 Kalefeld

Schweiz

Batrec AG
3752 Wimmis BE

Änderungen vorbehalten.

English

Safety Notes



Working safely with the measuring tool is possible only when the operating and safety information are read completely and the instructions contained therein are strictly followed. Never make warning labels on the measuring tool unrecognisable. SAVE THESE INSTRUCTIONS.

- **Caution – The use of other operating or adjusting equipment or the application of other processing methods than those mentioned here, can lead to dangerous radiation exposure.**

12 | English

- ▶ **The measuring tool is delivered with a warning label in English language (marked with the number 15 in the representation of the measuring tool on the graphic page).**

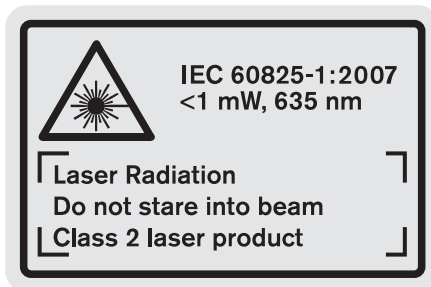

- ▶ **Do not direct the laser beam at persons or animals and do not stare into the laser beam yourself.** This measuring tool produces laser class 2 laser radiation according to IEC 60825-1. This can lead to persons being blinded.
- ▶ **Do not use the laser viewing glasses as safety goggles.** The laser viewing glasses are used for improved visualisation of the laser beam, but they do not protect against laser radiation.

- ▶ **Do not use the laser viewing glasses as sun glasses or in traffic.** The laser viewing glasses do not afford complete UV protection and reduce colour perception.
- ▶ **Have the measuring tool repaired only through qualified specialists using original spare parts.** This ensures that the safety of the measuring tool is maintained.
- ▶ **Do not allow children to use the laser measuring tool without supervision.** They could unintentionally blind other persons or themselves.
- ▶ **Do not operate the measuring tool in explosive environments, such as in the presence of flammable liquids, gases or dusts.** Sparks can be created in the measuring tool which may ignite the dust or fumes.

Product Description and Specifications

Please unfold the fold-out page with the representation of the measuring tool and leave it unfolded while reading the operating instructions.

Intended Use

The measuring tool is intended for measuring distances, lengths, heights, clearances, and for the calculation of areas and volumes. The measuring tool is suitable for measuring indoors and outdoors.

Technical Data

Digital Laser Rangefinder	GLM 50 Professional
Article number	3 601 K72 2..
Measuring range	0.05 – 50 m ^{A)}
Measuring accuracy (typically)	± 1.5 mm ^{B)}
Lowest indication unit	1 mm
Operating temperature	- 10 °C... +50 °C ^{C)}
Storage temperature	- 20 °C... + 70 °C
Relative air humidity, max.	90 %
Laser class	2
Laser type	635 nm, < 1 mW
Laser beam diameter (at 25 °C) approx.	
– at 10 m distance	6 mm
– at 50 m distance	35 mm
Automatic switch-off after approx.	
– Laser	20 s
– Measuring tool (without measurement)	5 min
Batteries	2 x 1.2 V LR03 (AAA)
Rechargeable batteries	2 x 1.2 V HR03 (AAA)
Battery live, approximately	
– Individual measurements	10 000 ^{D)}
– Continuous measurement	2.5 h ^{D)}
Weight according to EPTA-Procedure 01/2003	0.14 kg
Dimensions	53 x 114 x 30 mm
Degree of protection	IP 54 (dust and splash water protected)

A) The working range increases depending on how well the laser light is reflected from the surface of the target (scattered, not reflective) and with increased brightness of the laser point to the ambient light intensity (interior spaces, twilight). In unfavourable conditions (e.g. when measuring outdoors at intense sunlight), it may be necessary to use the target plate.

B) For measurements from the rear measuring-tool edge. In unfavourable conditions (e.g. at intense sunlight or an insufficiently reflecting surface), the maximum deviation is ± 10 mm per 50 m. In favourable conditions, a deviation influence of ± 0.05 mm/m must be taken into account.

C) In the continuous measurement function, the maximum operating temperature is $+40$ °C.

D) Less measurements are possible when using 1.2 V rechargeable batteries than with 1.5 V batteries. The battery life listed refers to measurements without display illumination.

Please observe the article number on the type plate of your measuring tool. The trade names of the individual measuring tools may vary.

The measuring tool can be clearly identified with the serial number **13** on the type plate.

Product Features





The numbering of the product features shown refers to the illustration of the measuring tool on the graphic page.

- 1 Display
- 2 Measuring button
- 3 Button for area/surface, volume and indirect height measurement (Pythagoras)
- 4 Delete / On/Off button **
- 5 Minus button
- 6 Button for selection of the reference level
- 7 Fixture for carrying strap
- 8 Plus button
- 9 Length and continuous measurement button
- 10 Battery lid
- 11 Laser beam outlet
- 12 Reception lens
- 13 Serial number
- 14 1/4" thread
- 15 Laser warning label
- 16 Latch of battery lid
- 17 Protective pouch
- 18 Tripod*
- 19 Laser viewing glasses*
- 20 Laser target plate*

* The accessories illustrated or described are not included as standard delivery.

** Keep button pressed to call up the extended functions.

Display Elements

- a Measured-value lines
- b Result line
- c Measuring functions
 -  Length measurement
 -  Continuous measurement
 -  Area/surface measurement
 -  Volume measurement
 -  Simple Pythagoras Measurement
- d Laser, switched on
- e Measurement reference level
- f Temperature warning

g Battery low indicator

h "ERROR" indication

Assembly

Inserting/Replacing the Battery

Using alkali-manganese or rechargeable batteries is recommended for operation of the measuring tool.

Less measurements are possible when using 1.2 V rechargeable batteries than with 1.5 V batteries.

To open the battery lid **10**, press the latch **16** and remove the battery lid. Insert the batteries/rechargeable batteries. When inserting, pay attention to the correct polarity according to the representation on the inside of the battery compartment.

When inserting the batteries/rechargeable batteries, pay attention to the correct polarity according to the representation on the inside of the battery compartment.

When the battery symbol  appears for the first time on the display, at least 100 individual measurements are still possible. The continuous measurement mode is deactivated.

When the battery symbol  flashes, the batteries/rechargeable batteries must be replaced. Measurements are no longer possible.

Always replace all batteries/rechargeable batteries at the same time. Do not use different brands or types of batteries/rechargeable batteries together.

► **Remove the batteries/rechargeable batteries from the measuring tool when not using it for longer periods.**

When storing for longer periods, the batteries/rechargeable batteries can corrode and discharge themselves.

Operation

Initial Operation

► **Do not leave the switched on measuring tool unattended and switch the measuring tool off after use.** Other persons could be blinded by the laser beam.

► **Protect the measuring tool against moisture and direct sun light.**

► **Do not subject the measuring tool to extreme temperatures or variations in temperature.** As an example, do not leave it in vehicles for longer periods. In case of large variations in temperature, allow the measuring tool to adjust to the ambient temperature before putting it into operation.

14 | English

ation. In case of extreme temperatures or variations in temperature, the accuracy of the measuring tool can be impaired.

- ▶ **Avoid heavy impact to or falling down of the measuring tool.** After severe exterior effects to the measuring tool, it is recommended to carry out an accuracy check (see "Accuracy Check of the Distance Measurement", page 16) each time before continuing to work.

Switching On and Off

For **switching on** the measuring tool, the following possibilities are given:

- Pressing the On/Off button **4**: The measuring tool is switched on and is in length measurement mode. The laser is not activated.
- Pressing the measuring button **2**: Measuring tool and laser are switched on. The measuring tool is in length measurement mode.
- ▶ **Do not point the laser beam at persons or animals and do not look into the laser beam yourself, not even from a large distance.**

To **switch off** the measuring tool, press the On/Off button **4** for a few seconds.

When no button on the measuring tool is pressed for approx. 5 minutes, the measuring tool automatically switches off to save the batteries.

Measuring Procedure

After switching on by pressing the measuring button **2**, the measuring tool is always in length measurement mode. Other measuring modes can be switched to by pressing the respective function/mode button (see "Measuring Functions", page 14).

After switching on, the rear edge of the measuring tool is preset as the reference level for the measurement. By pressing the reference level button **6**, the reference level can be changed (see "Selecting the Reference Level", page 14).

Place the measuring tool with the selected reference plane against the desired starting point of the measurement (e.g. a wall).

Briefly press the measuring button **2** to switch on the laser beam.

- ▶ **Do not point the laser beam at persons or animals and do not look into the laser beam yourself, not even from a large distance.**

Aim the laser beam at the target surface. Briefly press the measuring button **2** again to initiate the measurement.

In the continuous measurement mode, the measurement begins immediately upon switching on the function.

Typically, the measured value appears after 0.5 seconds and latest after 4 seconds. The duration of the measurement depends on the distance, the light conditions and the reflection properties of the target surface. The laser beam is switched off automatically upon completion of the measurement.

When no measurement has taken place approx. 20 seconds after sighting, the laser beam is switched off automatically to save the batteries.

Selecting the Reference Level (see figure A)

For the measurement, you can select between three different reference planes:

- The rear measuring-tool edge (e.g. when measuring onward from a wall),
- The front measuring-tool edge (e.g. when measuring onward from a table edge),
- The centre of thread **14** (e.g. for tripod measurements).

To select the reference level, press button **6** until the requested reference level is indicated on the display. Each time after switching on the measuring tool, the rear end of the measuring tool is preset as the reference level.

Display Illumination

The display illumination is automatically activated, depending on the ambient brightness. When no button is pressed after the display illumination switches on, it is dimmed to save the batteries.

Measuring Functions

Simple Length Measurement (see figure B)

For length measurements, press button **9** until the "length measurement" indication  appears on the display.



To switch the laser on and for measuring, briefly press the measuring button **2** once each time.

The measured value is displayed in the result line **b**.

For several subsequent length measurements, the last measured results are displayed in the measured-value lines **a**.

Area Measurement (see figure C)

For area/surface measurements, press button **3** until the indicator for area/surface measurement  appears on the display.

Afterwards, measure the length and the width, one after another, in the same manner as a length measurement. The laser beam remains switched on between both measurements.



Upon completion of the second measurement, the surface is automatically calculated and displayed in the result line **b**.

The individual measured values are displayed in the measured-value lines **a**.

Volume Measurement (see figure D)

For volume measurements, press button **3** until the indicator for volume measurement  appears on the display.



Afterwards, measure the length, width and the height, one after another, in the same manner as for a length measurement. The laser beam remains switched on between all three measurements.

Upon completion of the third measurement, the volume is automatically calculated and displayed in the result line **b**. The individual measured values are displayed in the measured-value lines **a**.

Values above 999999 m³ cannot be indicated; "ERROR" appears on the display. Divide the volume to be measured into individual measurements; their values can then be calculated separately and then summarized.

Continuous Measurement (Tracking) (see figure E)

For continuous measurements, the measuring tool can be moved relative to the target, whereby the measuring value is updated approx. every 0.5 seconds. In this manner, as an example, you can move a certain distance away from a wall, while the actual distance can always be read.

For continuous measurements, press button **9** until the indicator for continuous measurement \uparrow appears on the display. To start the continuous measurement, press the measuring button **2**.



The current measured value is displayed in the result line **b**.

Pressing the measuring button **2** ends the continuous measurement. The last measured value is displayed in the result line **b**. Pressing the measuring button **2** again restarts a continuous measuring run.

Continuous measurement automatically switches off after 5 min. The last measured value remains indicated in the result line **b**.

Indirect height measurement / Simple Pythagoras Measurement (see figure F)

The indirect height measurement is used to measure distances that cannot be measured directly because an obstacle would obstruct the laser beam or no target surface is available as a reflector. Correct results are achieved only when the right angles required for the respective measurement are exactly adhered to (Pythagorean Theorem).

Pay attention that the reference plane of the measurement (e.g. the rear edge of the measuring tool) remains exactly at the same location for all individual measurements within a measuring sequence.

The laser beam remains switched on between the individual measurements.

Press button **3** until the indication for simple Pythagoras measurement \sphericalangle appears on the display.

Measure distances "1" and "2" in this sequence as for a length measurement. Pay attention that a right angle exists between distance "1" and the sought distance "X".



Upon completion of the last measurement, the result for the sought distance "X" is displayed in the result line **b**. The individual measured values are displayed in the measured-value lines **a**.

Deleting Measured Values

Briefly pressing button **4** deletes the last individual measuring value determined in all measuring functions. Briefly pressing the button repeatedly deletes the individual measured values in reverse order.

Adding Measured Values

To add measuring values, firstly carry out a measurement. Then press the plus button **8**. For confirmation, "+" appears on the display.

To add volumes or areas/surfaces, press the plus button **8** after the first completed measuring process. For confirmation, "+" appears on the display left of the volume/area symbol. Then carry out a second measurement.

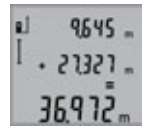

To call up the sum of both measurements, press the plus button **8** again. The calculation is indicated in the measured-value lines **a**, and the sum in the result line **b**.

After calculation of the sum, further measured values can be added to this result when pressing the plus button **8** prior to each measurement.

Notes on the addition:

- Mixed length, area/surface and volume values cannot be added together. For example, when a length and area value are added, "ERROR" briefly appears on the display after pressing the plus button **8**. Afterwards, the measuring tool switches back to the last active measuring mode.
- For each calculation, the result of one measurement is added (e.g. the volume value); for continuous measurements, this would be the displayed measured value in result line **b**. The addition of individual measured values from the measured-value lines **a** is not possible.

Subtracting Measured Values

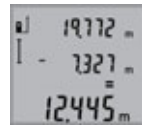

To subtract measuring values, press minus button **5**; For confirmation, "-" is indicated on the display. The further procedure is analog to "Adding Measured Values".

Working Advice

General Information

The reception lens **12** and the laser beam outlet **11** must not be covered when taking a measurement.

The measuring tool must not be moved while taking a measurement (with the exception of the continuous measurement function). Therefore, place the measuring tool, as far as this is possible, against or on a firm stop or supporting surface.

Influence Effects on the Measuring Range

The measuring range depends upon the light conditions and the reflection properties of the target surface. For improved visibility of the laser beam when working outdoors and when the sunlight is intense, use the laser viewing glasses **19** (accessory) and the laser target plate **20** (accessory), or shade off the target surface.

Influence Effects on the Measuring Result

Due to physical effects, faulty measurements cannot be excluded when measuring on different surfaces. Included here are:

- Transparent surfaces (e.g., glass, water),
- Reflecting surfaces (e.g., polished metal, glass),
- Porous surfaces (e.g. insulation materials),

16 | English

- Structured surfaces (e.g., roughcast, natural stone).

If required, use the laser target plate **20** (accessory) on these surfaces.

Furthermore, faulty measurements are also possible when sighting inclined target surfaces.

Also, air layers with varying temperatures or indirectly received reflections can affect the measured value.

Accuracy Check of the Distance Measurement

The accuracy of the distance measurement can be checked as follows:

- Select a permanently unchangeable measuring section with a length of approx. 1 to 10 metres; its length must be precisely known (e.g. the width of a room or a door opening). The measuring distance must be indoors; the target surface for the measurement must be smooth and reflect well.
- Measure the distance 10 times after another.

The deviation of the individual measurements from the mean value must not exceed ± 2 mm (max.). Log the measurements, so that you can compare their accuracy at a later point of time.

Working with the Tripod (Accessory)

The use of a tripod is particularly necessary for larger distances. Position the measuring tool with the 1/4" thread **14** onto the quick-change plate of the tripod **18** or a commercially available camera tripod. Tighten the measuring tool with the locking screw of the quick-change plate.

Set the corresponding reference level for measurement with a tripod by pushing button **6** (the reference level is the thread).

Troubleshooting – Causes and Corrective Measures

Cause	Corrective Measure
Temperature warning indicator (f) flashing; measurement not possible	
The measuring tool is outside the operating temperature range from -10 °C to $+50$ °C (in the function continuous measurement up to $+40$ °C).	Wait until the measuring tool has reached the operating temperature
“ERROR” indication in the display	
Addition/Subtraction of measured values with different units of measure	Only add/subtract measured values with the same units of measure
The angle between the laser beam and the target is too acute.	Enlarge the angle between the laser beam and the target
The target surface reflects too intensely (e.g. a mirror) or insufficiently (e.g. black fabric), or the ambient light is too bright.	Work with the laser target plate 20 (accessory)

Cause	Corrective Measure
The laser beam outlet 11 or the reception lens 12 are misted up (e.g. due to a rapid temperature change).	Wipe the laser beam outlet 11 and/or the reception lens 12 dry using a soft cloth
Calculated value is greater than 999999 m/m ² /m ³ .	Divide calculation into intermediate steps
Measuring result not plausible	
The target surface does not reflect correctly (e.g. water, glass).	Cover off the target surface
The laser beam outlet 11 or the reception lens 12 are covered.	Make sure that the laser beam outlet 11 or the reception lens 12 are unobstructed
Wrong reference level set	Select reference level that corresponds to measurement
Obstruction in path of laser beam	Laser point must be completely on target surface.
The indication remains unchanged or the measuring tool reacts unexpected after pressing a button	
Software error	Remove the batteries and start the measuring tool again after reinserting them.

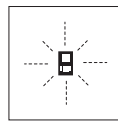

The measuring tool monitors the correct function for each measurement. When a defect is determined, only the symbol shown aside flashes in the display. In this case, or when the above mentioned corrective measures cannot correct an error, have the measuring tool checked by an after-sales service agent for Bosch power tools.

Maintenance and Service**Maintenance and Cleaning**

Store and transport the measuring tool only in the supplied protective pouch.

Keep the measuring tool clean at all times.

Do not immerse the measuring tool in water or other fluids.

Wipe off debris using a moist and soft cloth. Do not use any cleaning agents or solvents.

Maintain the reception lens **12** in particular, with the same care as required for eye glasses or the lens of a camera.

If the measuring tool should fail despite the care taken in manufacturing and testing procedures, repair should be carried out by an authorised after-sales service centre for Bosch power tools. Do not open the measuring tool yourself.

In all correspondence and spare parts orders, please always include the 10-digit article number given on the type plate of the measuring tool.

In case of repairs, send in the measuring tool packed in its protective pouch **17**.

After-sales Service and Customer Assistance

Our after-sales service responds to your questions concerning maintenance and repair of your product as well as spare parts. Exploded views and information on spare parts can also be found under:

www.bosch-pt.com

Our customer service representatives can answer your questions concerning possible applications and adjustment of products and accessories.

Great Britain

Robert Bosch Ltd. (B.S.C.)
P.O. Box 98
Broadwater Park
North Orbital Road
Denham
Uxbridge
UB 9 5HJ
Tel. Service: +44 (0844) 736 0109
Fax: +44 (0844) 736 0146
E-Mail: boschservicecentre@bosch.com

Ireland

Origo Ltd.
Unit 23 Magna Drive
Magna Business Park
City West
Dublin 24
Tel. Service: +353 (01) 4 66 67 00
Fax: +353 (01) 4 66 68 88

Australia, New Zealand and Pacific Islands

Robert Bosch Australia Pty. Ltd.
Power Tools
Locked Bag 66
Clayton South VIC 3169
Customer Contact Center
Inside Australia:
Phone: +61 (01300) 307 044
Fax: +61 (01300) 307 045
Inside New Zealand:
Phone: +64 (0800) 543 353
Fax: +64 (0800) 428 570
Outside AU and NZ:
Phone: +61 (03) 9541 5555
www.bosch.com.au

Republic of South Africa

Customer service
Hotline: +27 (011) 6 51 96 00

Gauteng – BSC Service Centre

35 Roper Street, New Centre
Johannesburg
Tel.: +27 (011) 4 93 93 75
Fax: +27 (011) 4 93 01 26
E-Mail: bsctools@icon.co.za

KZN – BSC Service Centre

Unit E, Almar Centre
143 Crompton Street
Pinetown
Tel.: +27 (031) 7 01 21 20
Fax: +27 (031) 7 01 24 46
E-Mail: bsc.dur@za.bosch.com

Western Cape – BSC Service Centre

Democracy Way, Prosperity Park
Milnerton
Tel.: +27 (021) 5 51 25 77
Fax: +27 (021) 5 51 32 23
E-Mail: bsc@zsd.co.za

Bosch Headquarters

Midrand, Gauteng
Tel.: +27 (011) 6 51 96 00
Fax: +27 (011) 6 51 98 80
E-Mail: rbsa-hq.pts@za.bosch.com

People's Republic of China**China Mainland**

Bosch Power Tools (China) Co., Ltd.
567, Bin Kang Road
Bin Jiang District 310052
Hangzhou, P.R. China
Service Hotline: 400 826 8484
Fax: +86 571 8777 4502
E-Mail: contact.ptcn@cn.bosch.com
www.bosch-pt.com.cn

HK and Macau Special Administrative Regions

Robert Bosch Hong Kong Co. Ltd.
21st Floor, 625 King's Road
North Point, Hong Kong
Customer Service Hotline: +852 2101 0235
Fax: +852 2590 9762
E-Mail: info@hk.bosch.com
www.bosch-pt.com.hk

Indonesia

PT. Multi Mayaka
Kawasan Industri Pulogadung
Jalan Rawa Gelam III No. 2
Jakarta 13930
Indonesia
Tel.: +62 (21) 46 83 25 22
Fax: +62 (21) 46 82 86 45/68 23
E-Mail: sales@multimayaka.co.id
www.bosch-pt.co.id

Philippines

Robert Bosch, Inc.
28th Floor Fort Legend Towers,
3rd Avenue corner 31st Street,
Fort Bonifacio Global City,
1634 Taguig City, Philippines
Tel.: +63 (2) 870 3871
Fax: +63 (2) 870 3870
matheus.contiero@ph.bosch.com
www.bosch-pt.com.ph